

Silencers

Leading the way in noise reduction.



Silencers Overview

Providing quieter workplaces and residential environments in urban and regional areas

ECI Silencers

Intake and exhaust silencers are designed and manufactured to suit all types of engines including locomotives, stationary generators, pumping sets, compressors, ships, mining equipment, diesel and gas powered transport, construction equipment and gas turbines. ECI's comprehensive product range includes both reactive and absorptive designs suitable for industrial, residential and super critical levels of sound attenuation.

Cowl Silencers

Spiral high performance and compact exhaust systems are ideal for environments where space is limited. Suitable for confined spaces in marine environments, mining or construction equipment. These silencers have a spiral chamber configuration that allows free flow of gas through a uniform cross section, they are partially lined with stainless steel wool and mesh. Noise is diffused and progressively attenuated as exhaust gas passes through the Cowl silencer.



Stainless Steel Silencers

In harsh and corrosive environments, quality stainless steel provides longevity and durability. Over time, emitted gases from the engine and natural corrosion from the elements will eventually rust a standard mild steel exhaust system. This process is escalated rapidly in the salt air and corrosive environments found in mining, quarries, marine and waste industries.

Working with 304 and 316 grade steel, the entire range of ECI exhausts, emission reduction equipment and acoustic products can be supplied in stainless steel. All our stainless steel solutions are manufactured here in Australia to the highest levels of quality control. Stainless steel is your most cost-effective choice.



Explosion Resistant Silencers

We have a comprehensive range of specifically designed explosion resistant silencers for gas engines and critical industry requirements; from 40NB-600NB as standard to custom sizes. All units are available in mild steel, with 304 and 316 grade stainless steel options for marine or corrosive environments.

ECI's design includes assessment criteria for thickness of shell and formed end material designed to withstand pressure of a detonation of unburnt fuel. Each silencer is issued with an ECI Certificate of Conformance upon delivery.

This criteria is in line with the following codes:

- AS3814-2015 Industrial Gas Appliance
- AS1210-2010 Pressure Vessel
- AS1375- 2013 SAA Industrial Fuel Fired Appliances



Since 1982, ECI has developed, manufactured and installed thousands of silencers across the country for industries such as: gas-fired power generation, mining, oil and petroleum, critical healthcare and marine. We refine our designs in line with changing regulations.

Features:

- ✓ All welded construction of HRCQ mild steel
- ✓ Option for construction in stainless steel 304/316
- ✓ Domed ends as standard
- ✓ Coated in heat-resistant paint for corrosion resistance
- ✓ Can be mounted either vertically or horizontally without affecting performance

Options:

- ✓ Factory customisation available
- ✓ Spark arrestor Inlet/Outlet configurations
- ✓ 316L stainless steel construction
- ✓ Flange connections variations
- ✓ A choice of exterior finishes
- ✓ A selection of accessories and mounting brackets
- ✓ Explosion resistant for AS3814 for gas engines
- ✓ Optional hot aluminised spray on mild steel versions, for long lasting corrosion resistances

Silencer Specifications

ECI uses dB(A) as an abbreviation for an expression of the relative loudness of sounds in the air as perceived by the human ear.



SA | ECI Absorptive Silencer | 20 dB(A) reduction

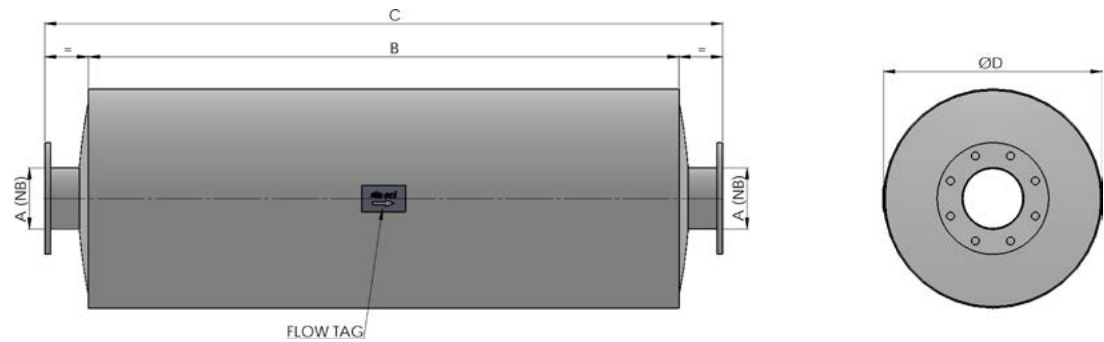

The ECI Absorptive Silencer is a medium straight through absorption silencer for all applications where low pressure drop is essential. Also, used in applications as secondary silencers where noise criterion is important.

A (NB)	B	C	ØD	EST (kg)
50	700	860	150	6
65	850	1060	230	16
80	824	1090	250	18
100	1134	1420	250	27
125	1340	1570	300	36
150	1434	1730	380	57
200	1408	1730	450	82
250	1718	2030	550	113
300	2018	2340	650	181
350	2374	2720	750	241
400	2688	3000	850	300
450	3064	3400	950	350
500	3438	3800	1050	400
550	3738	4100	1150	450
600	4138	4500	1130	500

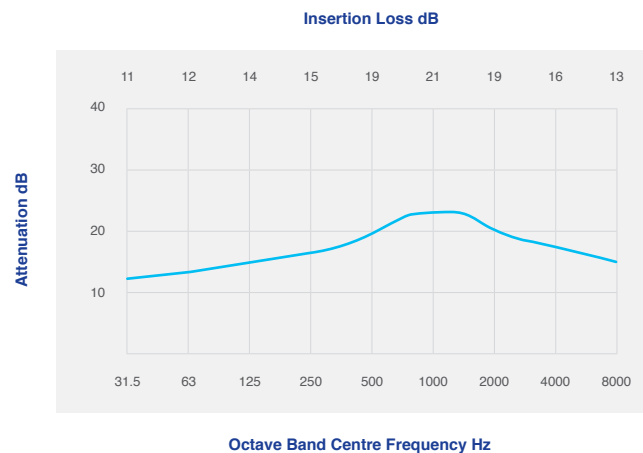

SI | ECI Industrial Silencer | 25 dB(A) reduction

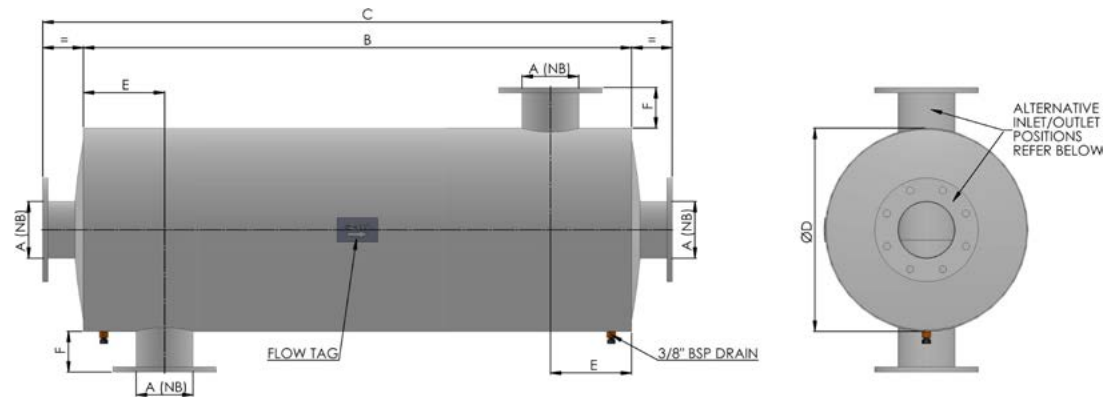

The ECI Industrial series of silencers are medium degree reactive silencers for use in environments where background noise is relatively high. Can be used with two and four cycle diesel engines.

A (NB)	B	C	ØD	E	F	EST (kg)
80	450	660	300	95	75	30
100	586	810	350	193	75	33
125	724	960	400	187	75	51
150	798	1060	450	194	75	68
200	1088	1400	560	244	100	115
250	1158	1470	660	294	100	172
300	1364	1700	760	332	100	233
350	1544	1880	910	382	100	330
400	1674	2010	1020	432	100	500
450	1978	2340	1170	479	100	680
500	2198	2560	1270	529	100	775
550	2428	2790	1370	579	100	985
600	2678	3040	1520	629	100	1130
650	2888	3250	1630	679	100	1350
700	3268	3630	1730	729	100	1640

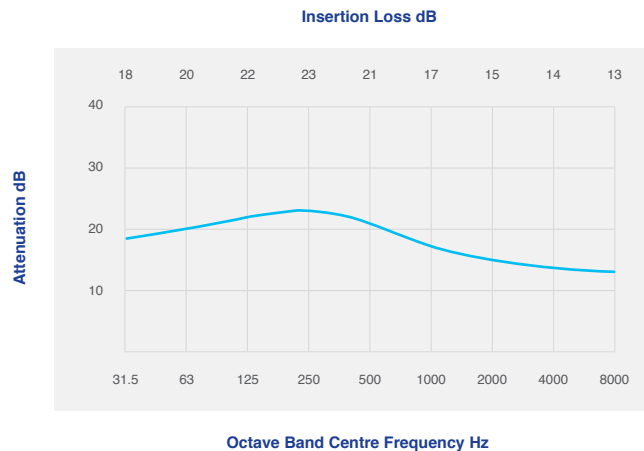

SR | ECI Residential Silencer | 30 dB(A) reduction

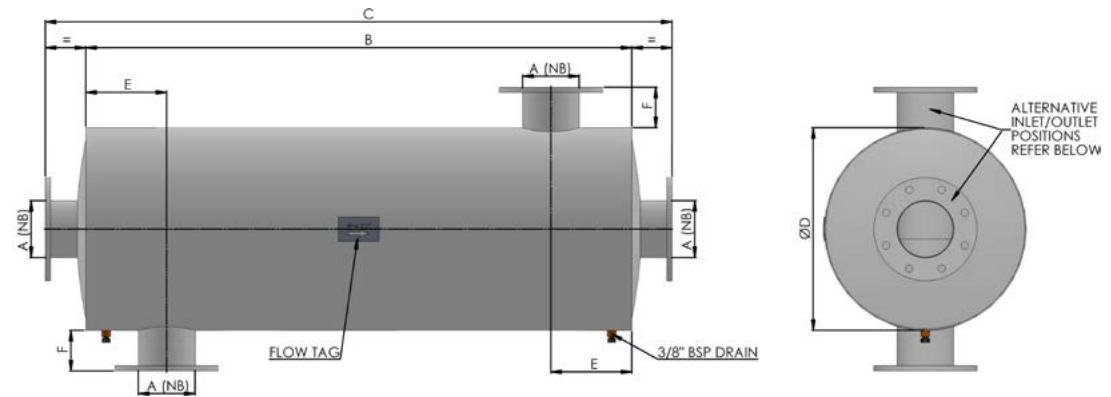

The ECI Residential Silencer is a high performance reactive silencer, recommended for those conditions where the ambient noise level in the environment is low. For use with two and four cycle diesel engines.

A (NB)	B	C	ØD	E	F	EST (kg)
40	690	900	200	95	75	25
50	829	1065	250	107	75	31
65	960	1170	300	120	75	35
80	996	1220	350	138	75	43
100	1054	1290	400	187	75	56
125	1288	1550	450	174	75	82
150	1413	1675	550	194	75	123
200	1718	2005	660	244	100	189
250	2204	2515	760	282	100	320
300	2604	2920	915	332	100	465
350	3164	3475	1020	382	100	640
400	3698	4060	1220	419	100	1030
450	4468	4870	1470	469	120	1250
500	5388	5840	1720	519	145	1794
550	6498	7015	2060	579	180	2070
600	7828	8420	2450	629	215	3025

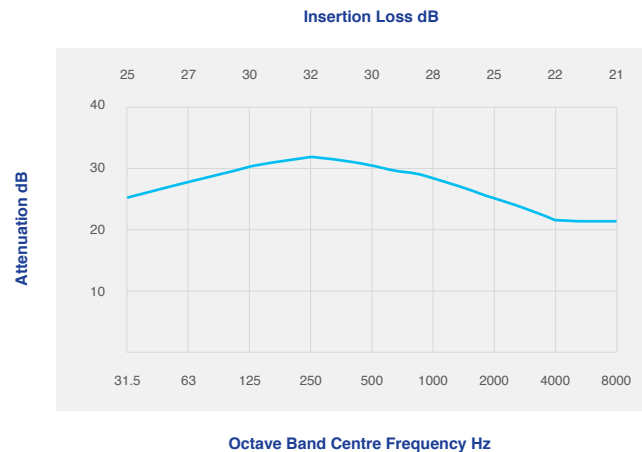

SC | **ECI Super Critical Silencer** | 35 dB(A) reduction

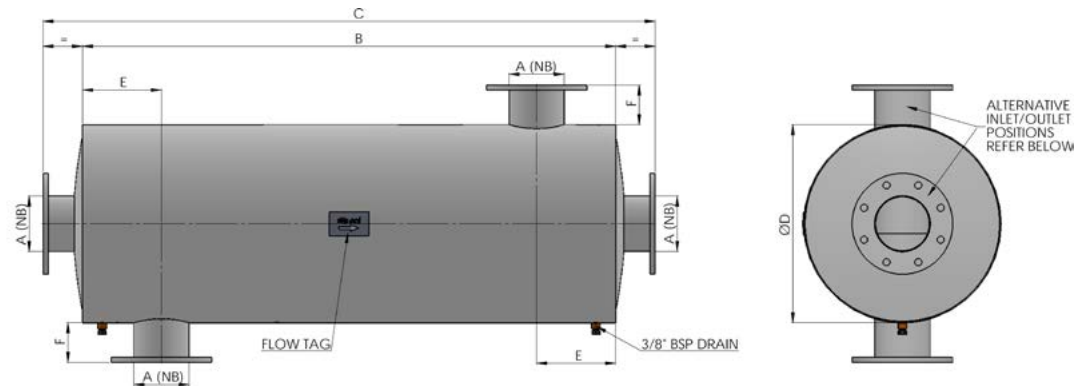

A high-performing reactive absorptive silencer recommended for those conditions where stringent noise criterion is demanded. It offers excellent broad band attenuation and is particularly effective. For use with two and four cycle engines. Customised sizes available.

A (NB)	B	C	ØD	E	F	EST (kg)
40	690	900	250	95	75	33
50	855	1065	300	120	75	38
65	946	1170	350	113	75	43
80	984	1220	400	132	75	53
100	1028	1290	450	174	75	68
125	1288	1550	500	174	75	95
150	1413	1675	600	194	75	140
200	1718	2005	750	244	100	215
250	2204	2515	850	282	100	363
300	2604	2920	1020	332	100	530
350	3164	3475	1120	382	100	715
400	3698	4060	1320	419	100	1030
450	4108	4470	1470	469	100	1250
500	4508	4870	1570	519	100	1794
550	4918	5280	1720	579	100	2070
600	5338	5700	1830	629	100	3025

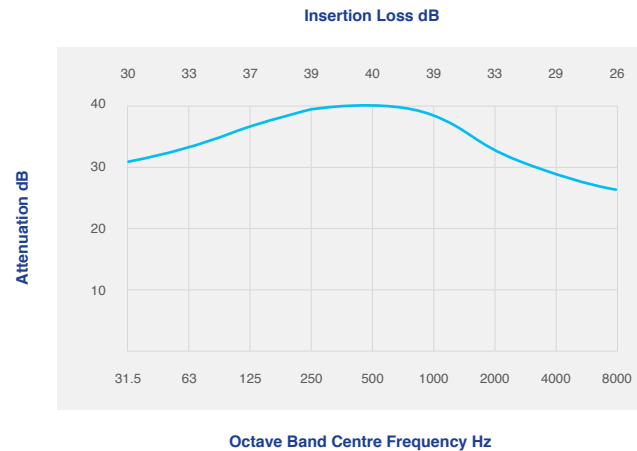

SC-FL | ECI Super Critical Fully Lined Silencer | 38 dB(A) reduction

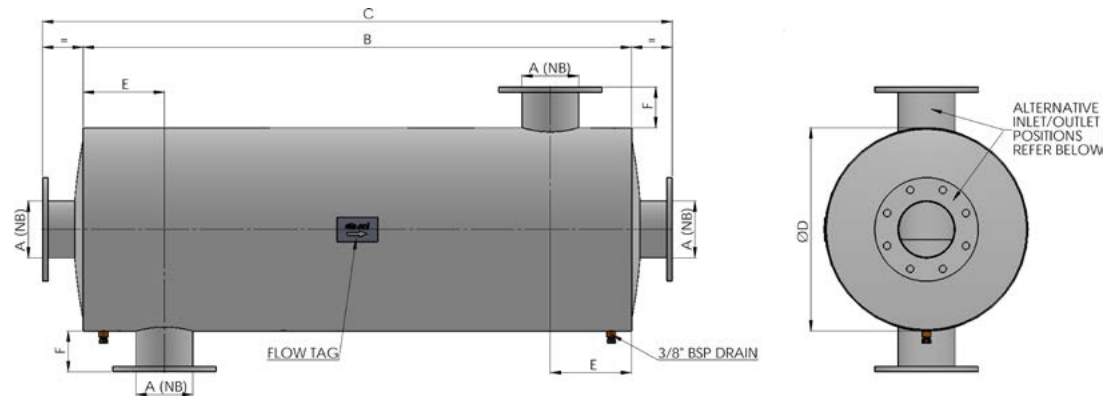

An acoustic lining made from a noise-absorbing substance is added to both chambers of the silencer. This ensures a higher level of sound attenuation can be reached.

A (NB)	B	C	ØD	E	F	EST (kg)
40	690	900	250	95	75	38
50	855	1065	300	120	75	44
65	946	1170	350	113	75	50
80	984	1220	400	132	75	61
100	1028	1290	450	174	75	78
125	1288	1550	500	174	75	110
150	1413	1675	600	194	75	160
200	1718	2005	750	244	100	248
250	2204	2515	850	282	100	418
300	2604	2920	1020	332	100	610
350	3164	3475	1120	382	100	822
400	3698	4060	1320	419	100	1185
450	4108	4470	1470	469	100	1438
500	4508	4870	1570	519	100	2064
550	4918	5280	1720	579	100	2380
600	5338	5700	1830	629	100	3480

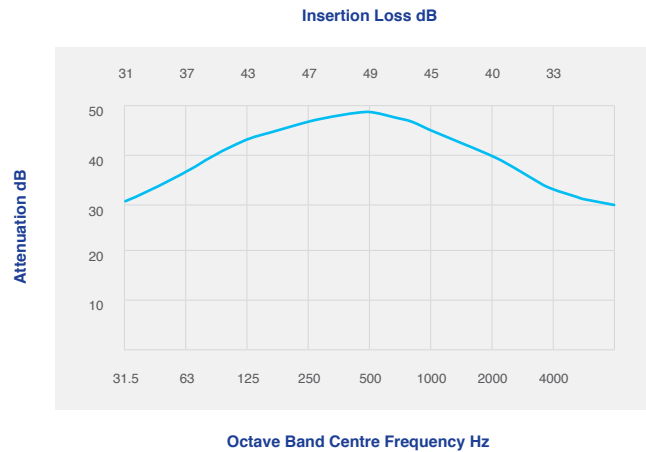

SC-FL-LT | **ECI Super Critical Fully Lined with Lined Tubes** | 42 dB(A) reduction

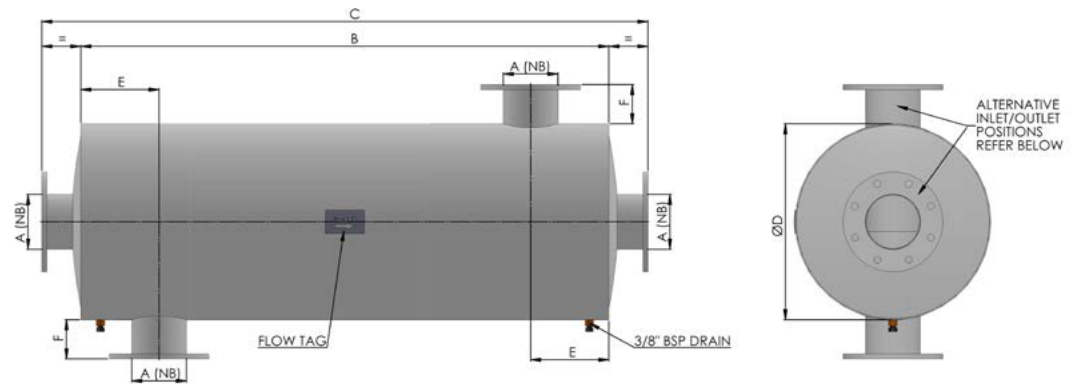

An acoustic lining is added to both chambers, the inlet and outlet, and inner tubes of the silencer. A noise-absorbing substance is used in the acoustic lining to ensure a premium level of sound attenuation can be attained.

A (NB)	B	C	ØD	E	F	EST (kg)
40	690	900	250	95	75	42
50	855	1065	300	120	75	48
65	946	1170	350	113	75	54
80	984	1220	400	132	75	66
100	1028	1290	450	174	75	85
125	1288	1550	500	174	75	118
150	1413	1675	600	194	75	175
200	1718	2005	750	244	100	270
250	2204	2515	850	282	100	454
300	2604	2920	1020	332	100	663
350	3164	3475	1120	382	100	894
400	3698	4060	1320	419	100	1288
450	4108	4470	1470	469	100	1562
500	4508	4870	1570	519	100	2242
550	4918	5280	1720	579	100	2588
600	5338	5700	1830	629	100	2780

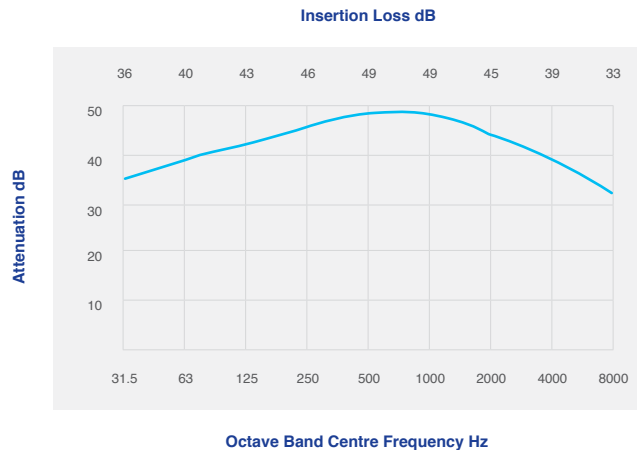

ECI Cowl Silencers

The ECI Cowl Silencer series includes high performance reactive silencers recommended for conditions where the ambient noise levels are low or very low, space is limited, and size or weight is critical. This compact design allows a silencer to fit into limited spaces such as marine vessels, cranes, fork lifts and anywhere size and weight is an issue.



Features:

- ✓ Compact spiral chamber design
- ✓ Low back pressure
- ✓ Low weight
- ✓ Aluminised steel construction to 650°C
- ✓ Standard high temperature finish
- ✓ Cost effective solution
- ✓ All MIG welded construction
- ✓ Steel wool and mesh liner
- ✓ Slip-fit connections standard
- ✓ Available in stainless steel as an option
- ✓ Ideal for tight spatial confines.

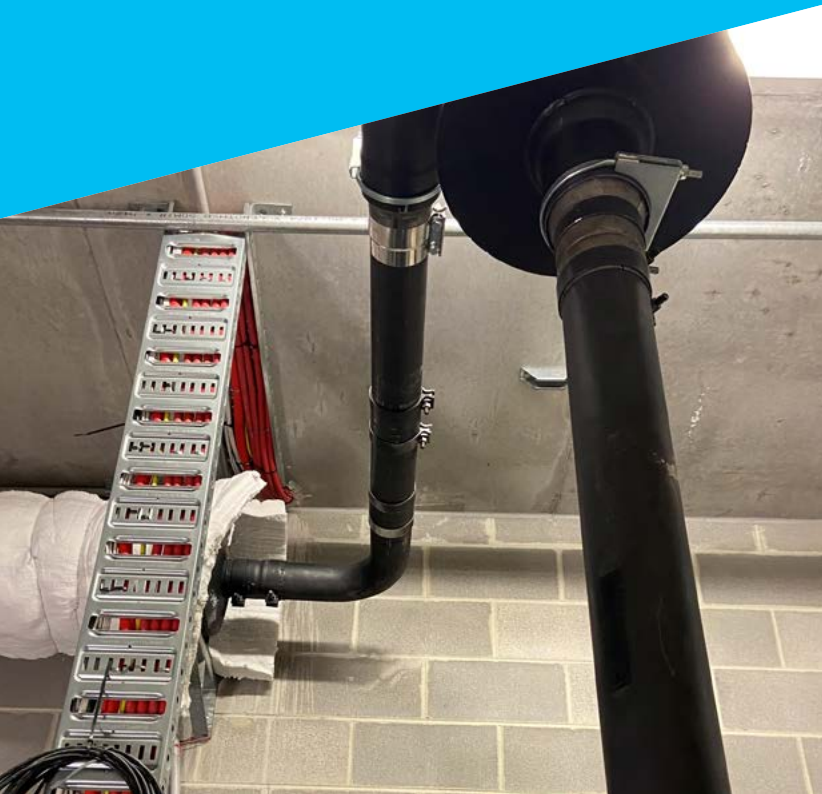

TXS | ECI Critical Cowl Silencer | 28-33 dB(A) reduction

A compact design that allows silencer to fit into critical applications where space or weight is limited. Recommended for those conditions when the ambient noise level in the environment is very low.

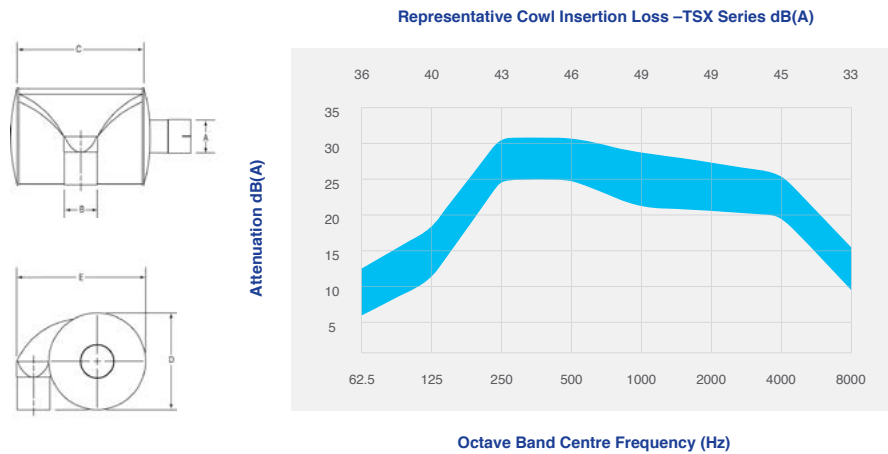

Inlet A dia. (I.D.)	Outlet B dia. (O.D.)	C	D	E	EST (kg)
38	38	133	224	255	6
51	51	184	224	266	8
64	64	209	300	347	14
76	76	235	408	462	24
89	89	292	408	473	28
102	102	393	408	494	34
114	114	317	492	592	37
127	127	419	492	604	44
152	152	571	492	628	57
203	203	391	673	867	64
203	203	618	673	876	98
254	254	764	864	1101	159
305	305	916	1016	1289	232

TS | ECI Residential Cowl Silencer | 22-28 dB(A) reduction

A compact design that ensures fit where size and weight is limited. Recommended for those conditions when the ambient noise level in the environment is low.

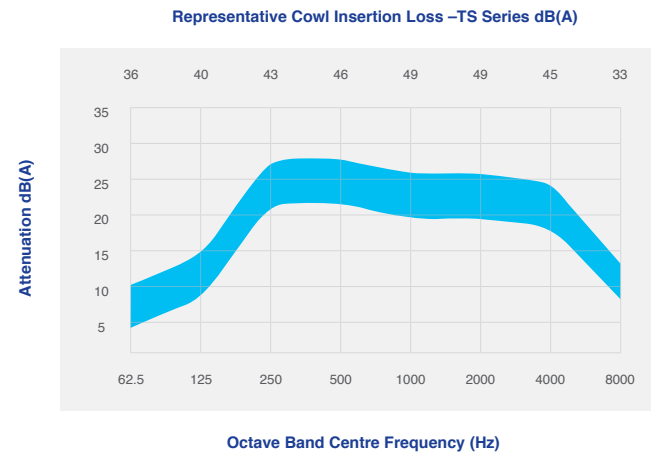

Inlet A dia. (I.D.)	Outlet B dia. (O.D.)	C	D	E	EST (kg)
38	38	133	182	217	5
51	51	184	182	230	7
64	64	209	224	283	9
76	76	235	300	369	14
89	89	292	300	379	18
102	102	393	300	400	21
114	114	317	408	518	30
127	127	419	408	529	33
152	152	571	408	552	42
203	203	390	559	755	46
203	203	616	559	755	70
254	254	764	711	944	114
305	305	916	838	1122	166

Noise reduction

ECI provide solutions to further reduce noise and sound outputs. Enclosures, acoustic silencers, acoustic doors and linings, noise barriers, paneling and noise attenuation louvres reduce outputs to acceptable levels.



ECI Acoustic Products

ECI design, manufacture and install acoustic products for a wide cross section of applications. Noise reducing products are used in critical acoustic applications for the reduction of unacceptable noise levels from diesel and gas engines. Dropover, base mounted and containerised acoustic enclosures can be produced in any material and customised to any requirement.

- ✓ Custom engine canopies and containers
- ✓ Plant rooms for generators, compressors and diesel fire pumps
- ✓ Acoustic barriers, linings and treatments
- ✓ Low noise silencer options
- ✓ Attenuators
- ✓ Canopies also available in modular form for assembly onsite

Thermal Insulation Products

Thermal insulation products are commonly used in diesel applications, power pumps and dewatering, mining, marine applications, fire pumps, and power generation.



Exhaust Wraps

Generally used on smaller diameter exhausts or tight radius pipes, wraps provide an entry level and cost-effective way to reduce engine heat, by retaining the combustion heat within the exhaust pipe run. This aids the flow of gases in the exhaust system and prevents thermal loss to other parts of the engine. Used when minimum clearances can be problematic.



Exhaust Blankets and Soft Lagging

The custom-made blankets are used to retain exhaust gas temperatures when utilised with emission treatments such as purifiers, DPFs and SCRs. The blankets, when installed correctly, assist in lowering engine temperatures by reducing radiant heat discharge into the canopy or plantroom, and on to other engine components. Cooler engine or plantroom temperatures provide greater engine performance, reduced fuel consumption and safer working conditions for operators and mechanical staff. They provide physical barriers against noise, heat exposure and contact burns. Commonly used in marine, locomotive, mining, on-highway and power generation where exhaust movement and vibration could be encountered. Exhaust maintenance and inspections are straight forward because removal takes only minutes.

Thermal Insulation Products



Hard lagging

Hard lagging is used in fixed commercial installations where it is critical to retain exhaust temperatures within the pipe run, and eliminate radiant heat discharge.

Hard lagging provides the best possible physical barrier to prevent staff injury and damaged equipment. Also, the lagging maintains all levels of temperature that the site or engine may require. This provides operational efficiencies, as it guards against atmospheric temperature variations and temperature variations within the equipment.

Commonly used in commercial buildings and corrosive environments like refineries and oil and gas facilities, hard lagging provides an aesthetically cleaner look to pipework, flanges and connections.

Hard lagging can have numerous insulation thicknesses and external casings can have cladding from zinalume, aluminum or stainless steel.



Guards

Guards are used when a shield is required for applications that are visible when operational and/or complex in shape. Exhaust guards provide a basic form of protection from accidental contact. They are generally not used when high levels of movement or vibration are encountered. A personalised laser cut guard can be designed to suit your requirements.

Australian manufactured, owned and operated – delivering our innovation and expertise across Australasia, South Pacific and Asia.



Exhaust Control Industries Pty Ltd

Head Office 29 – 33 Fonceca Street,
Mordialloc, Victoria, 3195 Australia

T+61 3 9588 2233 **F** +61 3 9588 2567

E eci@exhaustcontrol.com.au **ABN** 60 606 757 724

Brisbane 31 Flanders Street,
Salisbury Queensland 4107

Singapore 159F Tampines Road,
Singapore 535159

Toll Free

Australia 1800 730 158

Indonesia +0018 030 612 026

Asia +800 400 010 10

